

# **Procedures to file a request to the Austrian Patent Office (ÖPA) for Patent Prosecution Highway (PPH) Pilot Program between the ÖPA and the National Board of Patents and Registration of Finland (NBPR)**

## **PART 1: PPH using the national work products from the Office of First Filing (OFF)**

The PPH Pilot Program enables an application whose claims have been determined to be patentable in the OFF – NBPR - to undergo an accelerated examination in the Office of Second Filing (OSF) – ÖPA - with a simple procedure according to a request from an applicant.

### **1. Request to the ÖPA**

An applicant has to file a request for accelerated examination under the PPH to the ÖPA by submitting a bilingual German/English form for requesting accelerated examination under the PPH Pilot Program accompanied by the relevant supporting documents. The requirements for an application to the ÖPA for accelerated examination under the PPH are given in paragraph 2. Relevant supporting documentation (paragraph 3) and the general ÖPA application procedure envisaged at this time is discussed in the following section (paragraph 4).

### **2. Requirements for requesting accelerated examination under the PPH Pilot Program at the ÖPA**

There are four requirements for requesting accelerated examination under the PPH Pilot Program at the ÖPA. These are:

a) **The AT application (including PCT national phase applications) is:**

- i) an application which validly claims priority under the Paris Convention to the NBPR application(s) (examples are provided in Annex 1, figure A, B, C, D, E and F), or
- ii) a PCT national phase application without priority claim (direct PCT applications) (examples are provided in Annex 1, figure G), or
- iii) an application which validly claims priority under the Paris Convention to the PCT application(s) without priority claim (examples are provided in Annex 1, figure H, I and J).

An AT application which validly claims priority to multiple FI or PCT applications, or which is a divisional application validly based on the originally filed application that is included in (i) to (iii) above, is also eligible.

b) **At least one corresponding FI application has one or more claims that have been determined to be patentable by the NBPR.**

c) **All claims in the AT application for accelerated examination under the PPH must sufficiently correspond to one or more of those claims indicated as patentable in the NBPR.**

Claims are considered to sufficiently correspond where both claims have a common technical feature which made the claims patentable over the prior art in the FI application. In this regard, a claim which has additional component on the claim determined to be patentable in the NBPR or which is the same except for claim format as the claim determined to be patentable in the NBPR will be considered to sufficiently correspond. Note that when claims are

determined to be patentable by the NBPR by making amendment to claims, the claims in the ÖPA also must be amended similar way to sufficiently correspond to the allowable/patentable claims in the FI application.

- d) **The ÖPA has not yet issued a decision to grant a patent ('Erteilungsbeschluss').**

### **3. Required documents for accelerated examination under the PPH Pilot Program at the ÖPA**

The following documentation will be needed to support a request for accelerated examination under the PPH Pilot Program at the ÖPA:

- a) **a copy of all office actions on the corresponding FI application(s) and translation(s) of them**

Both German and English are acceptable as translation languages. An applicant does not have to submit the copy and translation of the office actions when those documents are provided via the electronic dossier system of the NBPR. However, if the available (machine) translation is insufficient, the ÖPA examiner may request an additional translation from the applicant.

- b) **a copy of the claims examined by the NBPR and copies of subsequent amended claims found to be patentable by the NBPR where appropriate, and translation of them**

Both German and English are acceptable as translation languages. However, if the available (machine) translation is insufficient, the ÖPA examiner may request an additional translation from the applicant.

- c) **a completed claim correspondence table in German or English language showing the correspondence between the claims of the AT application for accelerated examination under the PPH and the claims of the corresponding FI application considered patentable by the NBPR**

Sufficient correspondence of claims occurs where the claims are of the same scope as defined above. When claims are just literal translation, the applicant can just write down that 'they are same' in the table. When claims are not just literal translation, it is necessary to explain the sufficient correspondence of each claim based on the criteria 2c).

- d) **a copy of the document(s) cited by the NBPR examiner in the reasons for refusal**

If the cited document is a patent document, it does not have to be submitted as it is generally available to the ÖPA via EPOQUE. Only if the ÖPA has difficulty in obtaining a patent document the Office will ask the applicant to submit it.

As a rule, cited documents need not be translated.

The applicant has to provide the relevant information by filling in a form for requesting accelerated examination under the PPH Pilot Program which is available for download from the ÖPA website. The form should be sent to the ÖPA along with the relevant supporting documentation.

If the applicant has already submitted the above documents 3a) to 3d) to the ÖPA through simultaneous or past procedures, the applicant can incorporate the documents by reference and does not have to attach them.

### **4. Procedure for accelerated examination under the PPH Pilot Program at the ÖPA**

The ÖPA decides whether the application can be entitled to the status for an accelerated examination under the PPH when it receives a request with the documents stated above. When the ÖPA decides that the request is acceptable, the application is assigned a special status for an accelerated examination under the PPH. In those instances where the request does not meet all the requirements set forth above, the applicant will be notified and the defects in the request will be identified. The applicant will be given opportunity to correct the request. If not corrected, the applicant will be notified and the application will await action in its regular turn.

## **PART 2: PPH using the PCT international work products (PCT- PPH)**

Under the PCT- PPH Pilot Program a PPH request can be based on the latest PCT work product (written opinion of the ISA (WO- ISA) or international preliminary examination report (IPER) established by the NBPR as ISA or IPEA, where this work product determines claims to be patentable/allowable.)

### **1. Request to the ÖPA**

An applicant has to file a request for accelerated examination under the PCT- PPH to the ÖPA by submitting a bilingual German/English form for requesting accelerated examination under the PCT- PPH Pilot Program accompanied by the relevant supporting documents. The requirements for an application to the ÖPA for accelerated examination under the PCT- PPH are given in paragraph 2. Relevant supporting documentation (paragraph 3) and the general ÖPA application procedure envisaged at this time is discussed in the following section (paragraph 4).

### **2. Requirements for requesting accelerated examination under the PCT- PPH Pilot Program at the ÖPA**

There are four requirements for requesting accelerated examination under the PCT- PPH Pilot Program at the ÖPA. These are:

- a) **The relationship between the AT application and the corresponding international application satisfies one of the following requirements** (including the case that the Office of the application is the same as the ISA/IPEA of the corresponding international application):
  - i) The application is a national phase application of the corresponding international application (examples are provided in Annex 2, figure A, A' and A'').
  - ii) The application is a national application as a basis of the priority claim of the corresponding international application (example is provided in Annex 2, figure B).
  - iii) The application is a national phase application of an international application claiming priority from the corresponding international application (example is provided in Annex 2, figure C).
  - iv) The application is a national application claiming foreign/domestic priority from the corresponding international application (example is provided in Annex 2, figure D).
  - v) The application is the derivative application (divisional application, application claiming internal priority, etc.) of the application which satisfies one of the above requirements (i) – (iv) (examples are provided in Annex 2, figures E1 and E2).
- b) **The AT application has one or more claim(s) that are determined to be patentable/allowable in the work product of the corresponding PCT application.**

The latest work product in the international phase of a PCT application corresponding to the application ("international work product"), namely the Written Opinion of International Searching Authority (WO/ISA) or the International Preliminary Examination Report (IPER), indicates at least one claim as patentable/allowable (from the aspect of novelty, inventive steps and industrial applicability). The applicant cannot file a request under PCT- PPH on the basis of an International Search Report (ISR) only.

In case any observation is described in Box VIII of WO/ISA, WO/IPEA or IPER which forms the basis of a PCT- PPH request, the applicant must explain why the claim(s) is/are not subject to the observation whether or not an amendment is submitted to correct the observation.

- c) **All claims on file, as originally filed or as amended, for examination under the PCT- PPH must sufficiently correspond to one or more of those claims indicated as patentable/allowable in the latest international work product of the corresponding international application.**

Claims are considered to sufficiently correspond where both claims have a common technical feature which made the claims patentable over the prior art in the PCT application. In this

regard, a claim which has additional component on the claim determined to be patentable in the corresponding PCT application or which is the same except for claim format as the claim determined to be patentable will be considered to sufficiently correspond. Note that when claims are determined to be patentable by making amendment to claims, the claims in the AT application also must be amended similar way to sufficiently correspond to the allowable/patentable claims in the PCT application.

- d) **The ÖPA has not yet issued a decision to grant a patent (‘Erteilungsbeschluss’).**

### **3. Required documents for accelerated examination under the PCT- PPH Pilot Program at the ÖPA**

The following documentation will be needed to support a request for accelerated examination under the PCT- PPH Pilot Program at the ÖPA:

- a) **a copy of the latest international work product of the corresponding international application and translation of it**

Both German and English are acceptable as translation languages. However, if the available (machine) translation is insufficient, the ÖPA examiner may request an additional translation from the applicant. If the copy of the latest international work product is available via “PATENTSCOPE”<sup>1</sup>, an applicant need not submit these documents, unless otherwise requested by the ÖPA (WO/ISA and IPER are usually available as “IPRP Chapter I” and “IPRP Chapter II” respectively in 30 months after the priority date.)

- b) **a copy of a set of claims which the latest international work product of the corresponding international application indicated as patentable/allowable, and translation of it**

Both German and English are acceptable as translation languages. However, if the available (machine) translation is insufficient, the ÖPA examiner may request an additional translation from the applicant. If the copy of the set of claims which are indicated as patentable/allowable is available via “PATENTSCOPE”, an applicant need not submit this document, unless otherwise requested by the ÖPA. Where translations of the patentable/allowable claims are necessary, they must be submitted by an applicant since “PATENTSCOPE” does not provide them.

- c) **a completed claim correspondence table in German or English language showing the correspondence between the claims of the AT application and the claims determined to be patentable/allowable in the latest work product of the corresponding international application**

Sufficient correspondence of claims occurs where the claims are of the same scope as defined above. When claims are just literal translation, the applicant can just write down that ‘they are same’ in the table. When claims are not just literal translation, it is necessary to explain the sufficient correspondence of each claim based on the criteria 2c).

- d) **copies of references cited in the latest international work product of the corresponding international application**

If the references are patent documents, the applicant doesn’t have to submit them because the office of the application usually possesses them. When the office of the application does not possess the patent document, the applicant has to submit the patent document at the examiner’s request. Non- patent literature must always be submitted.

The applicant has to provide the relevant information by filling in a form for requesting accelerated examination under the PCT- PPH Pilot Program which is available for download from the ÖPA website. The form should be sent to the ÖPA along with the relevant supporting documentation.

---

<sup>1</sup> <http://www.wipo.int/pctdb/en/index.jsp>

If the applicant has already submitted the above documents 3a) to 3d) to the ÖPA through simultaneous or past procedures, the applicant can incorporate the documents by reference and does not have to attach them.

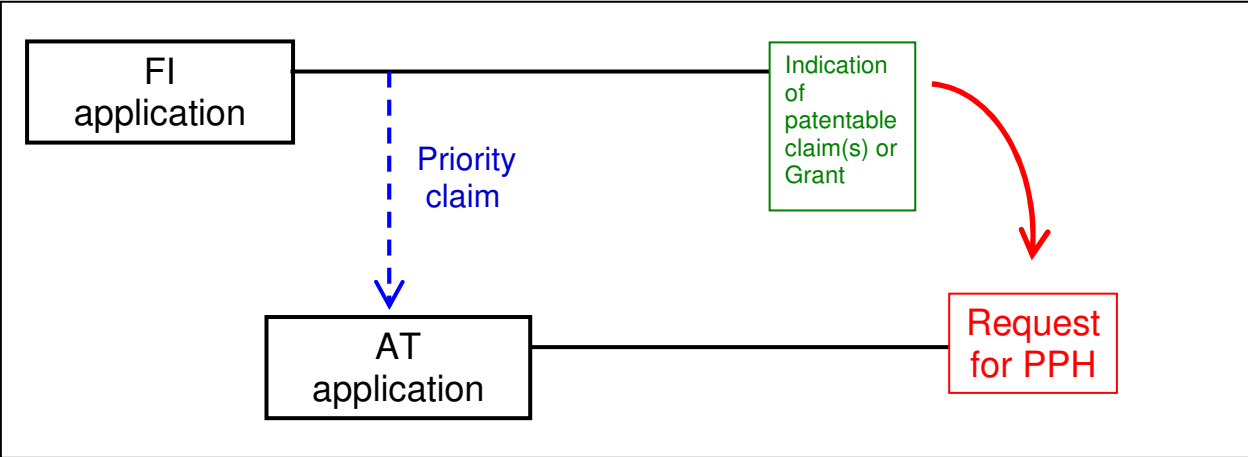
#### **4. Procedure for accelerated examination under the PCT- PPH Pilot Program at the ÖPA**

The ÖPA decides whether the application can be entitled to the status for an accelerated examination under the PCT- PPH when it receives a request with the documents stated above. When the ÖPA decides that the request is acceptable, the application is assigned a special status for an accelerated examination under the PCT- PPH. In those instances where the request does not meet all the requirements set forth above, the applicant will be notified and the defects in the request will be identified. The applicant will be given opportunity to correct the request. If not corrected, the applicant will be notified and the application will await action in its regular turn.

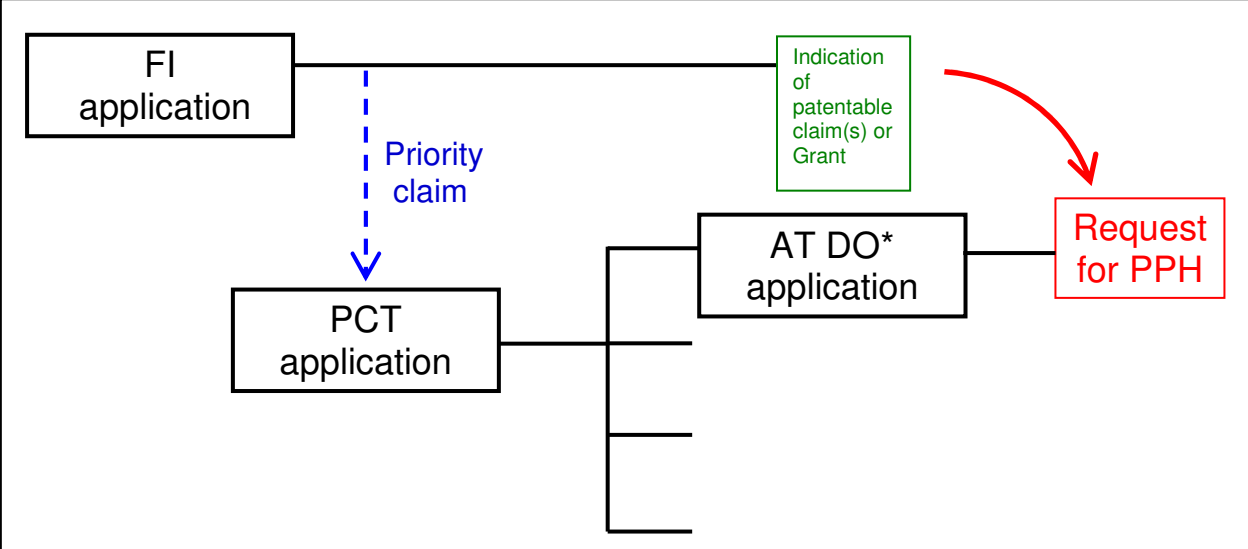
**ANNEX 1**

**Eligible for the PPH:**

**Figure A:**



**Figure B:**



\* DO – Designated Office

Figure C:

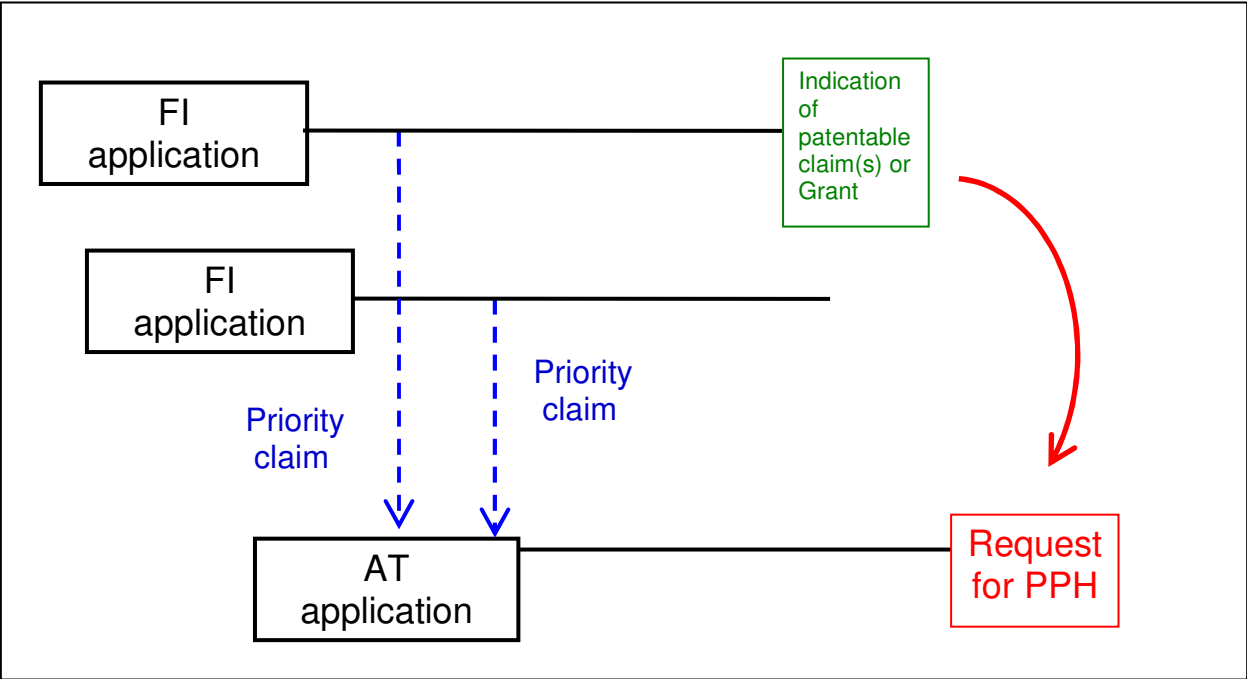


Figure D:

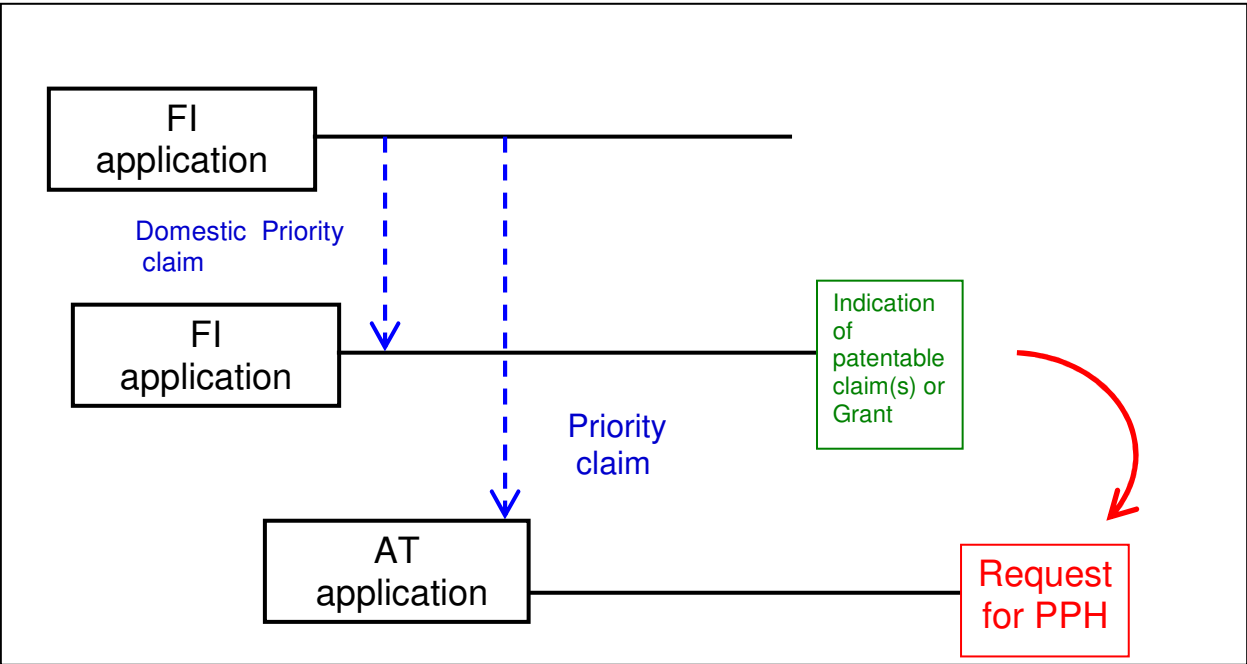


Figure E:

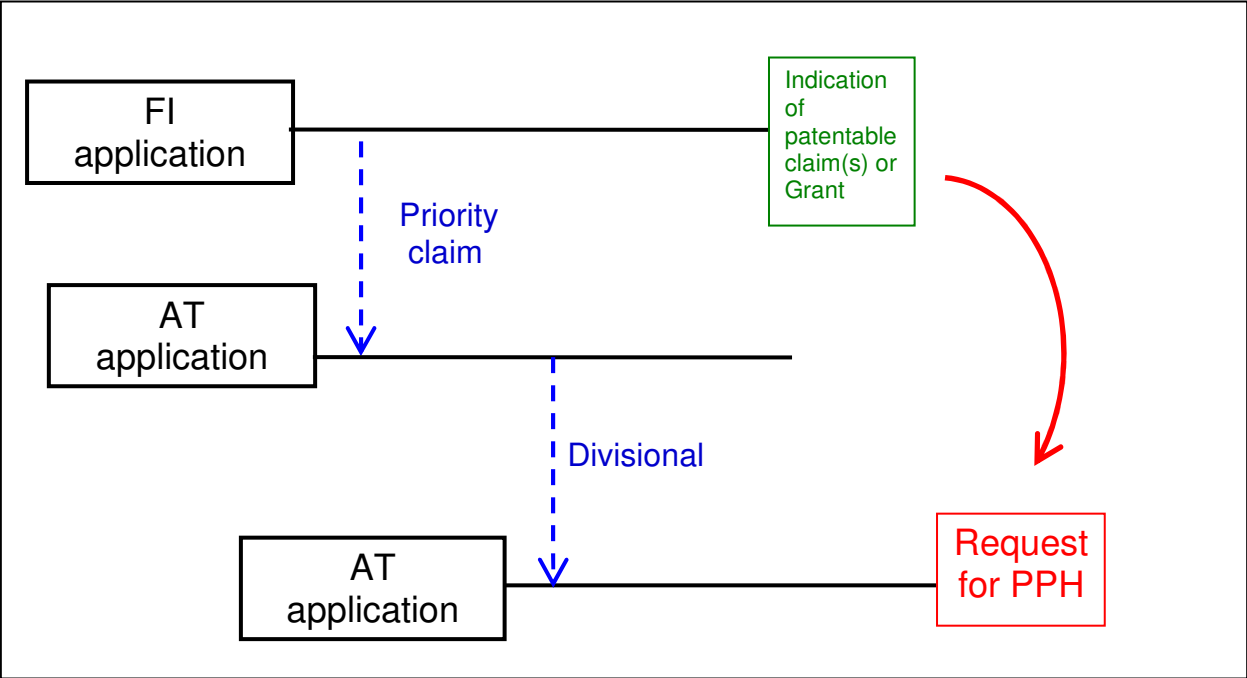


Figure F:

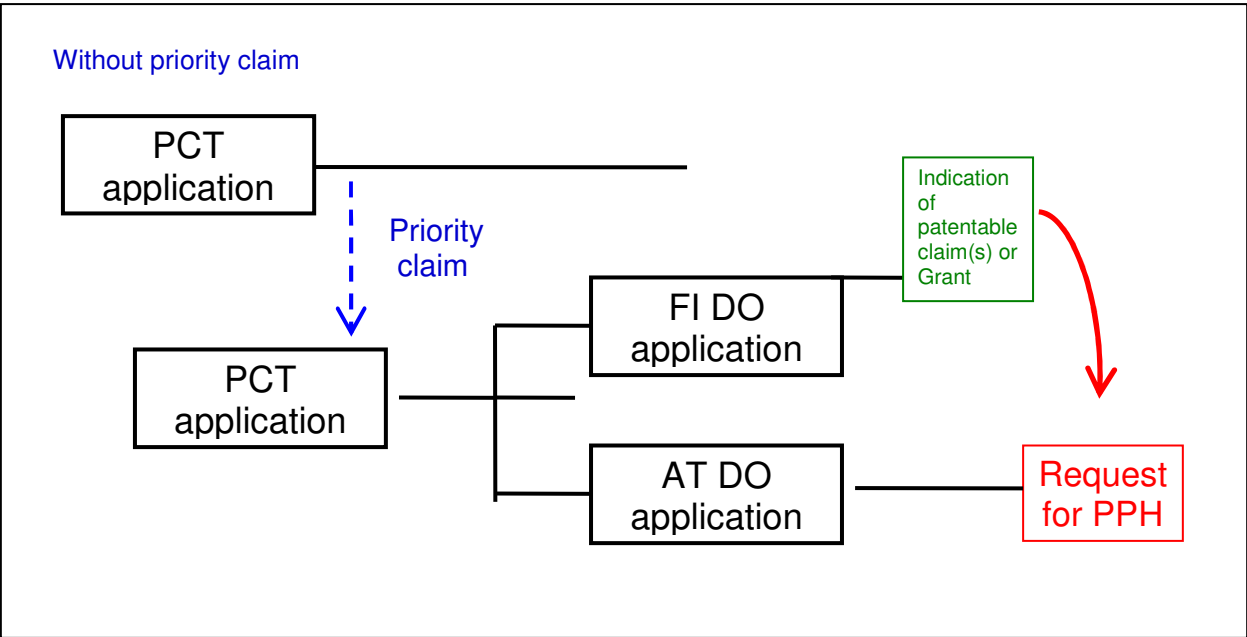


Figure G:

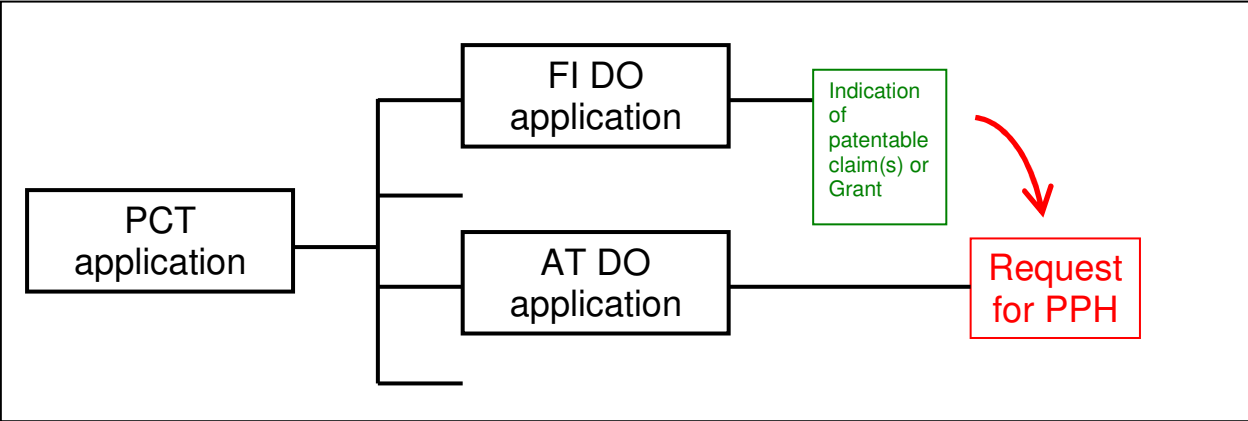


Figure H:

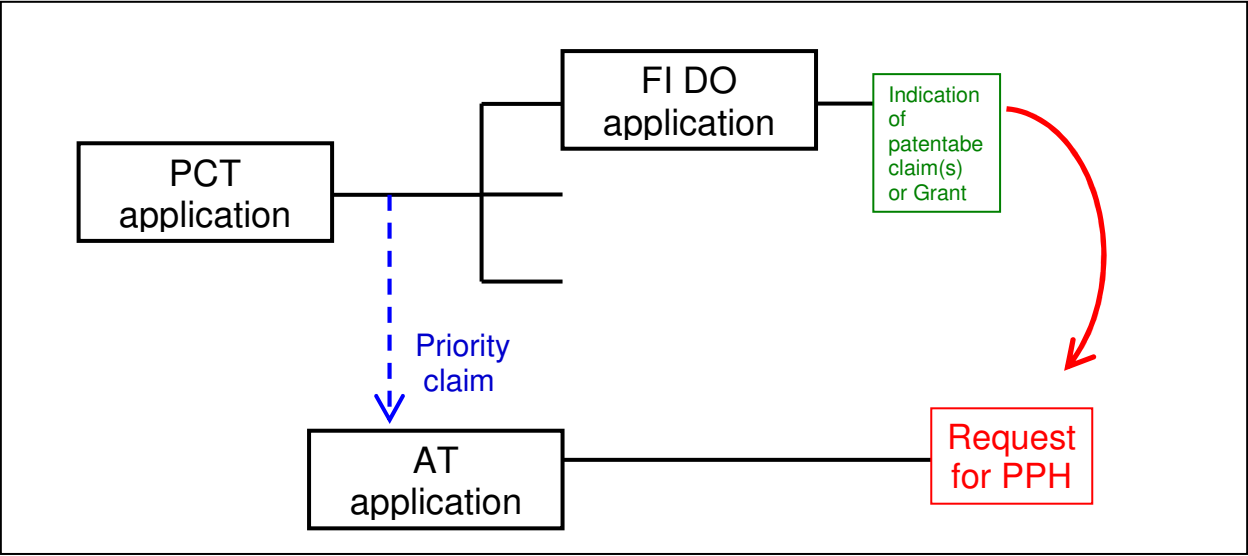


Figure I:

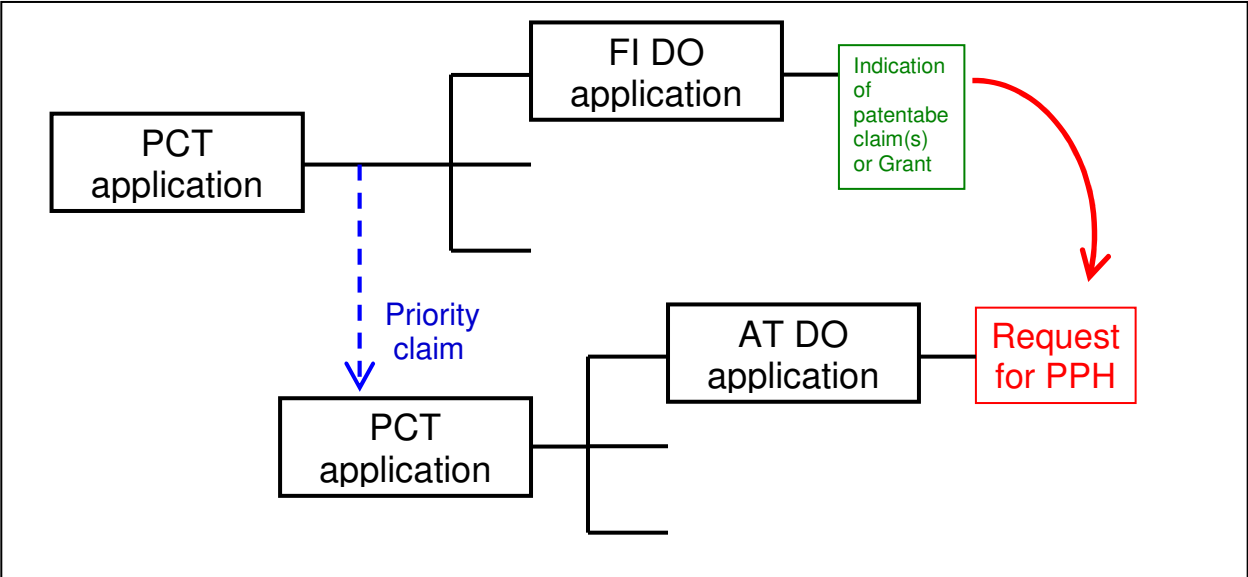
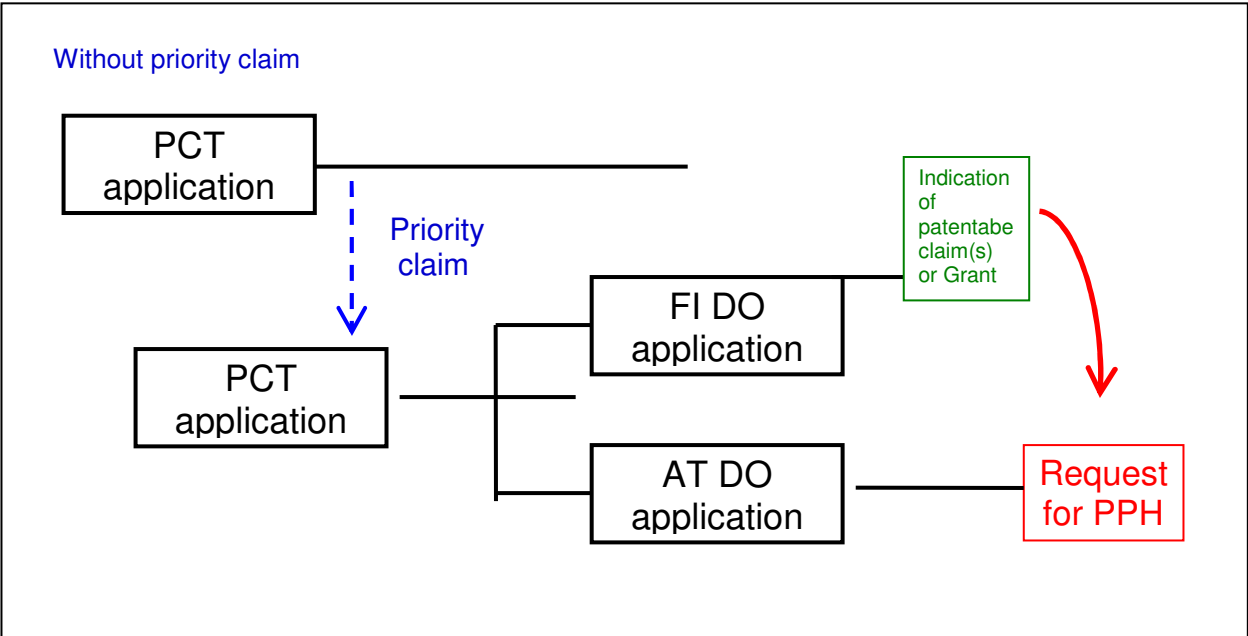


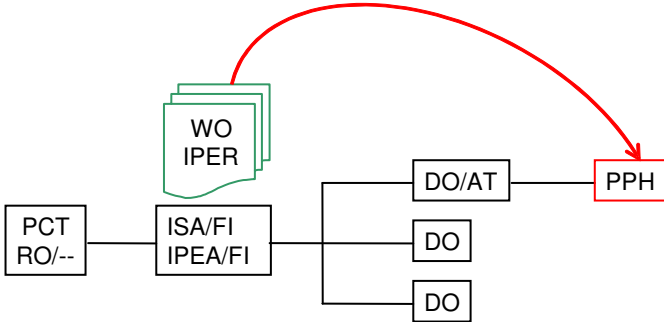
Figure J:



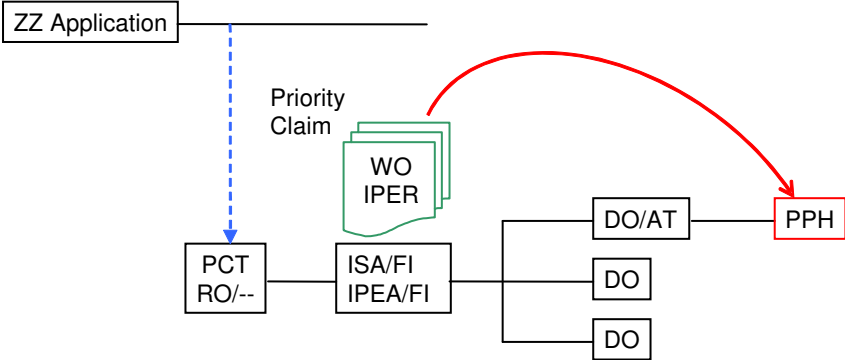
**ANNEX 2**

**Eligible for the PCT-PPH**

**Figure (A)**

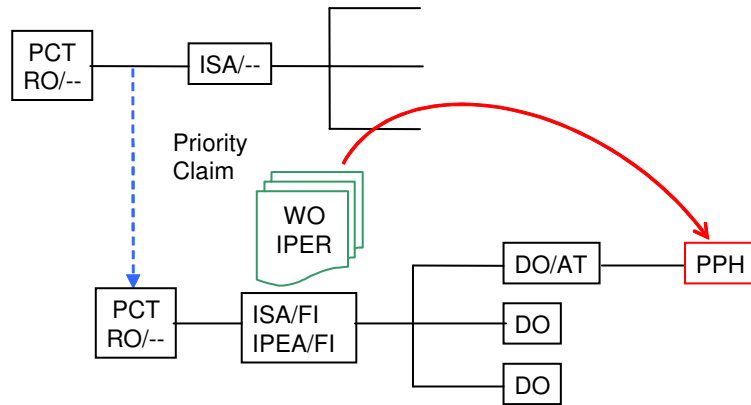


**Figure (A')**  
**(The corresponding international application claims priority from a national application.)**

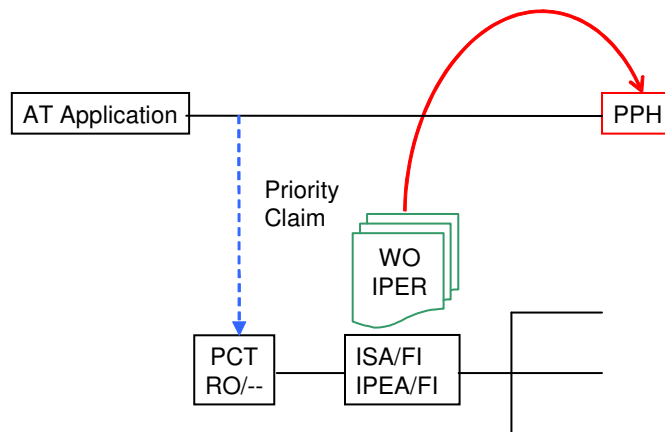


**Figure (A'')**

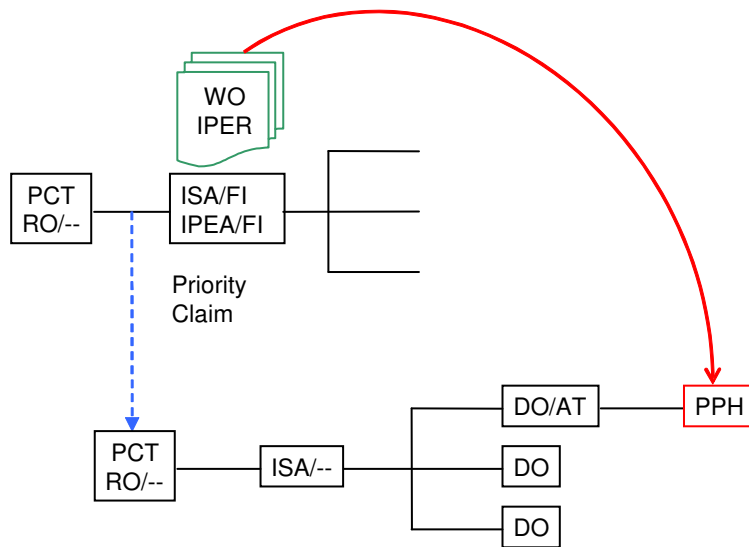
**(The corresponding international application<sup>n</sup> claims priority from an international application.)**



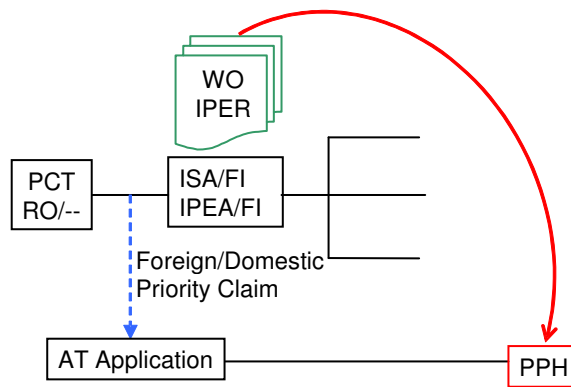
**Figure (B)**



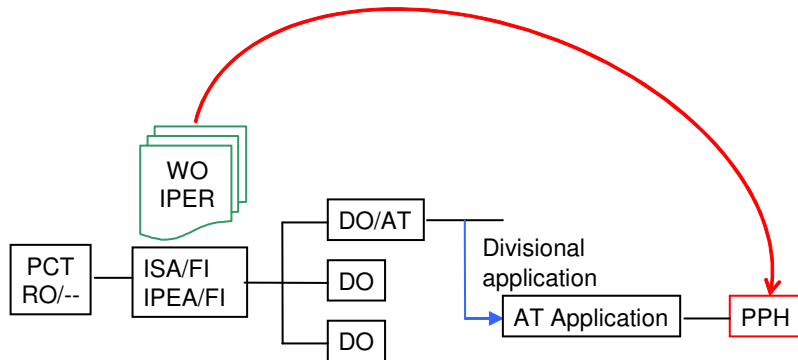
**Figure (C)**



**Figure (D)**



**Figure (E1): The application is a divisional application of an application which satisfies the requirement (A).**



**Figure (E2): The application is an application claiming domestic priority from an application which satisfies the requirement (B).**

