

Procedures to file a request to the
National Board of Patents and Registration of Finland
for the
Patent Prosecution Highway
Pilot Program between the
United States Patent and Trademark Office
and the
National Board of Patents and Registration of Finland

Background

National Board of Patent and Registration of Finland (NBPR) and United States Patent and Trademark Office (USPTO) implemented a Patent Prosecution Highway (PPH) pilot program on 6. July, 2009.

Under the current PPH scheme, the Office of first filing (OFF) has to provide its examination results before any of the other offices accept PPH requests. This principle puts a restriction on making PPH requests and prevents subsequent offices from fully utilizing the results of examinations conducted in the other offices, due to the fact that the OFF does not always conduct the examinations before the Office of second filing (OSFs) do theirs.

In order to improve the PPH program and make it available to a wider range of applicants, the NBPR and the USPTO have agreed to revise the requirements for requesting participation in the PPH pilot program. The revised requirements and the trial period are set forth below and supersede all prior PPH notices between the NBPR and the USPTO.

Under the PPH MOTTAINAI Pilot, an applicant can make PPH requests at the Office of Later Examination (OLE) by using the examination results of the Office of Earlier Examination (OEE), provided that the OEE and OLE have a PPH MOTTAINAI agreement.

The PPH MOTTAINAI pilot will commence on 15 July, 2011, for a period of one year ending on 14 July 2012. The pilot period may be extended if necessary. The offices will bilaterally determine whether and how the program should be fully implemented at the end of the pilot period.

Request to the NBPR

An applicant should file a request for accelerated examination under the Patent Prosecution Highway (PPH) to the National Board of Patents and Registration of Finland (NBPR) by submitting a letter requesting accelerated examination under the PPH accompanied by the relevant supporting documents. The requirements for an application to the NBPR for accelerated examination under either the PPH or the PCT-PPH are given in sections 1 and 4 and relevant supporting documentation is discussed in sections 2 and 5.

The request form is available online at the NBPR PPH website at <http://www.prh.fi/en/patentit/pph.html>.

Part 1: PPH using the national work products from USPTO

1. Requirements for requesting accelerated examination under the PPH pilot program at the NBPR

1.1 Both the NBPR application on which PPH is requested and the USPTO application(s) forming the basis of the PPH request shall have the same earliest date (whether this be a priority date or a filing date).

For example, the NBPR application (including PCT national phase application) may be either:

(Case I) an application which validly claims priority under the Paris Convention from the USPTO application(s) (examples are provided in ANNEX 1, Figure A, B, C and D), or

(Case II) an application which provides the basis of a valid priority claim under the Paris Convention for the USPTO application(s) (including PCT national phase application(s)) (examples are provided in ANNEX 1, Figure E, F and G), or

(Case III) an application which shares a common priority document with the USPTO application(s) (including PCT national phase application(s)) (examples are provided in ANNEX 1, Figure H, I, J, K and L), or

(Case IV) a PCT national phase application where both the NBPR application and the USPTO application(s) are derived from a common PCT international application having no priority claim (an example is provided in ANNEX 1, Figure M).

The NBPR application, which validly claims priority to multiple USPTO or PCT

applications, or which is the divisional application validly based on the originally filed application that is included in (I) to (IV) above, is also eligible.

1.2 At least one corresponding application exists in the USPTO and has one or more claims that are determined to be patentable/allowable by the USPTO

Claims clearly identified to be patentable in the latest office action at examination stage are able to function as the basis for a request for accelerated examination under the PPH pilot program. This is the case even though the application, which includes those claims, is not granted for patent yet. An USPTO office action includes a “Non-Final Rejection”, “Final Rejection”, “Ex parte Quayle”, and a “Notice of Allowability”.

1.3 All claims in the NBPR application (for which an accelerated examination under the PPH pilot program is requested) must sufficiently correspond to one or more of those claims determined to be patentable/allowable in the USPTO.

Claims are considered to "sufficiently correspond" where, accounting for differences due to translations and claim format, the claims in the NBPR are of the same or similar scope as the claims in the USPTO, or the claims in the NBPR are narrower in scope than the claims in the USPTO.

In this regard, a claim that is narrower in scope occurs when a USPTO claim is amended to be further limited by an additional feature that is supported in the specification (description and/or claims).

A claim in the NBPR which introduces a new/different category of claims to those claims indicated as allowable in the USPTO is not considered to sufficiently correspond. For example, if the USPTO claims only contain claims to a process of manufacturing a product, then the claims in the NBPR are not considered to sufficiently correspond if the NBPR claims introduce product claims that are dependent on the corresponding process claims.

1.4 The NBPR has not yet issued a “Communication of Approval”

The NBPR has not yet issued a “Communication of Approval.” (The heading of the communication is “Hyväksyvä välipäätös.”)

2. Documents to be submitted to file a request for accelerated examination under the PPH

An applicant who requests for accelerated examination under the PPH should submit a request form along with the documents listed below.

[Note]

Even when it is not needed to submit documents below, the name of the documents must be listed in the request form.

2.1 A copy of the office action(s) relating to the corresponding USPTO application(s)

The term “office actions” here used refers to the correspondence sent to the applicant or the applicant’s representative from the USPTO examiner. The applicant can either provide the office actions together with the request for acceleration under the PPH or request that the NBPR obtain the documents from the USPTO Public PAIR system.

It is noted that applicants must also submit copies of any office actions (which are relevant to patentability) from the USPTO application(s) issued after the grant of the request for participation in the PPH pilot program in the NBPR (especially where USPTO might have reversed a prior holding of allowability/patentability).

2.2 A copy of the claims determined to be patentable by the USPTO including any subsequent amended claims found to be patentable by the USPTO

The applicant can either provide the claims together with the request for acceleration under the PPH or request that the NBPR obtain the claims from the USPTO Public PAIR system.

2.3 A copy of the references cited by the USPTO examiner

If the references are patent documents, it will not be necessary to submit these documents, as they will usually be available to the NBPR. If the NBPR does not have access to the relevant patent documents, the applicant must submit these documents at the request of the NBPR. Non-patent literature must always be submitted.

Submission of translation of the references is not required. However, applicants will be

free to file translations as part of the supporting documentation when initially requesting accelerated examination under the PPH to allow prompt consideration of the citations if the applicants so desire.

2.4 A completed claim correspondence table showing the relationship between the claims of the NBPR application for accelerated examination under the PPH and the claims of the corresponding USPTO application considered patentable by the USPTO.

Sufficient correspondence of claims occurs where the claims are of the same or similar scope as defined above in section 1.3. The claim correspondence table must indicate how all the claims in the NBPR application correspond to the patentable claims in the USPTO application. The claim correspondence table must be written in either English or Finnish.

Any claims amended or added after the grant of the request for participation in the PPH pilot program must sufficiently correspond to one or more allowable/patentable claims in the USPTO application(s). The applicant is required to submit a new claims correspondence table along with the amendments. If the amended or newly added claims do not sufficiently correspond to the allowable/patentable claims in the USPTO application(s), the amendment will not be entered.

2.5 When the US file wrapper is not available via USPTO Public PAIR

In those rare situations where the US application has not been published, and therefore the US file wrapper is not available via the USPTO Public PAIR system, the applicant will be responsible for providing the necessary documents to the NBPR.

Part 2: PPH using the PCT international work products

4. Requirements

The application which is filed with the NBPR and on which the applicant files a request for an accelerated examination under the PCT-PPH must satisfy the following requirements:

4.1 The relationship between the application and the corresponding international application

The relationship between the application and the corresponding international application satisfies one of the following requirements (including the case that the Office of the application is the same as the ISA/IPEA of the corresponding international application):

(A) The application is a national phase application of the corresponding international application (examples are provided in Annex 2: figures A, A', and A'').

(B) The application is a national application as a basis of the priority claim of the corresponding international application (example is provided in Annex 2: figure B).

(C) The application is a national phase application of an international application claiming priority from the corresponding international application (example is provided in Annex 2: figure C).

(D) The application is a national application claiming foreign/domestic priority from the corresponding international application (example is provided in Annex 2: figure D).

(E) The application is the derivative application (divisional application, application claiming internal priority, etc.) of the application which satisfies one of the above requirements (A) – (D) (examples are provided in Annex 2: figures E1 and E2).

4.2 The application has one or more claims that are determined to be patentable/allowable in the work product of the corresponding PCT application

The latest work product in the international phase of a PCT application corresponding to the application ("international work product"), namely the Written Opinion of International Searching Authority (WO/ISA), the Written Opinion of International Preliminary Examining Authority (WO/IPEA) or the International Preliminary Examination Report (IPER), indicates at least one claim as patentable/allowable (from the aspect of novelty,

inventive steps and industrial applicability). The applicant cannot file a request under PCT-PPH on the basis of an International Search Report (ISR) only.

In case any observation is described in Box VIII of WO/ISA, WO/IPEA or IPER which forms the basis of a PCT-PPH request, the applicant must explain why the claim(s) is/are not subject to the observation whether or not an amendment is submitted to correct the observation. The application will not be eligible for participating in PCT-PPH pilot program if the applicant does not explain why the claim(s) is/are not subject to the observation. In this regard, however, it does not affect the decision on the eligibility of the application, whether the explanation is adequate and/or whether the amendment submitted overcomes the observation.

Note that the ISA and the IPEA which produced the WO/ISA, WO/IPEA and the IPER must be the USPTO, but, if priority is claimed, the priority claim can be to an application in any Office, see Annex 2, example A' (application ZZ can be any national application).

4.3 Claim correspondence

All claims on file, as originally filed or as amended, for examination under the PCT-PPH must sufficiently correspond to one or more of those claims indicated as patentable/allowable in the latest international work product of the corresponding international application.

Claims are considered to sufficiently correspond where both claims have a common technical feature which made the claims patentable over the prior art in the latest international work product of the corresponding international application. In this regard, a claim which has an additional component on the claim determined to be patentable in the latest international work product, or which is the same apart from claim format as the claim determined to be patentable in the latest international work product, will be considered to sufficiently correspond.

A claim of the application which introduces a new/different category of claims to those claims indicated as patentable/allowable in the latest international work product is not considered to sufficiently correspond. For example, the claims indicated as patentable/allowable in the latest international work product only contain claims to a process of manufacturing a product, then the claims of the application are not considered to sufficiently correspond if the claims of the application introduce product claims that are dependent on the corresponding process claims.

Any claims amended or added after the grant of the request for participation in the PCT-PPH pilot program need to sufficiently correspond to the claims indicated as patentable/allowable in the latest international work product.

4.4 The office of the application has not yet issued a “Communication of Approval”

The NBPR has not yet issued a “Communication of Approval.” (The heading of the communication is “Hyväksyvä välipäätös.”)

5. Documents to be submitted to file a request for accelerated examination under the PCT-PPH

The applicant must submit the following documents attached to the request form in filing a request under PCT-PPH.

5.1 A copy of the latest international work product of the corresponding international application

In case the application satisfies the relationship 4.1 (A), the applicant does **not** need to submit a copy of the International Preliminary Report on Patentability (IPRP) because a copy of these documents is already available in the file-wrapper of the application. In addition, if the copy of the latest international work product is available via PATENTSCOPE^{®*}, an applicant does not need to submit these documents, unless otherwise requested by the patent Office (WO/ISA and IPER are usually available as “IPRP Chapter I” and “IPRP Chapter II” respectively in 30 months after the priority date.)

5.2 A copy of a set of claims which the latest international work product of the corresponding international application indicated as patentable/allowable

A copy of a set of claims which the latest international work product of the corresponding international application indicated as patentable/allowable, and a copy of the English or Finnish translation.

If the copy of the set of claims which are indicated as patentable/allowable is available via PATENTSCOPE[®] (or the international Patent Gazette has been published), an applicant does not need to submit this document, unless otherwise requested by the

patent Office. Where translations of the patentable/allowable claims are necessary, they must be submitted by the applicant since PATENTSCOPE[®] does not provide them.

5.3 Copies of references cited in the latest international work product of the corresponding international application

If the references are patent documents, the applicant does not have to submit them because the office of the application usually has access to them. When the office of the application does not have access to the patent document, the applicant has to submit the patent document at the examiner's request. Non-patent literature must always be submitted.

Submission of translation of the references is not required. However, applicants will be free to file translations as part of the supporting documentation when initially requesting accelerated examination under the PPH to allow prompt consideration of the citations if the applicants so desire.

5.4 Claim correspondence table

The applicant must submit a claim correspondence table to explain the correspondence of claims determined to be patentable/allowable in the latest work product of the corresponding international application and all claims in the application.

When the applicant has already submitted the documents mentioned above in paragraphs 5.1 – 5.4 to the patent Office in an examination procedure of the patent family application, through simultaneous or past procedures, the applicant may incorporate the documents by reference and is thus not required to attach the documents.

5.5 Request form

An applicant should submit a request form (See Annex 4) for the accelerated examination under the PCT-PPH along with the documents referred to in paragraphs 5.1-5.4.

Procedure for the accelerated examination under the PPH

The applicant files a letter requesting accelerated examination under the PPH Pilot Program to the NBPR, including the relevant supporting documents and a completed request form (for PPH see Annex 3 and for PCT-PPH see Annex 4).

The NBPR decides whether the application can be entitled the status of accelerated examination under the PPH when NBPR receives a request with the documents stated above. When NBPR decides that a request is acceptable, the application is assigned a special status for accelerated examination.

If the request does not meet all the requirements set forth above, the applicant will be notified and the defects in the request will be identified. The applicant will be given opportunity to correct the request. If the defect(s) are not corrected, the applicant will be notified, and the application will await action in its regular turn.

ANNEX 1

Examples of NBPR applications eligible for PPH

A

(Case I)
- Paris route -

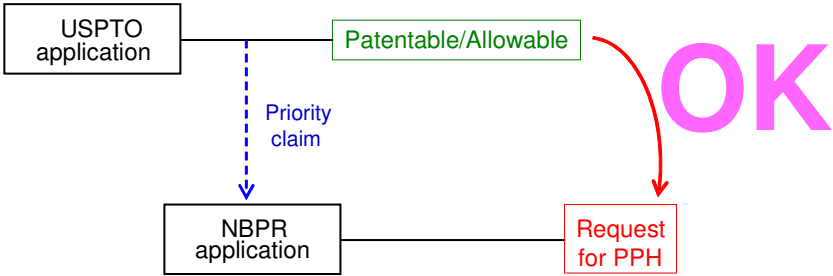

B

(Case I)
- PCT route -

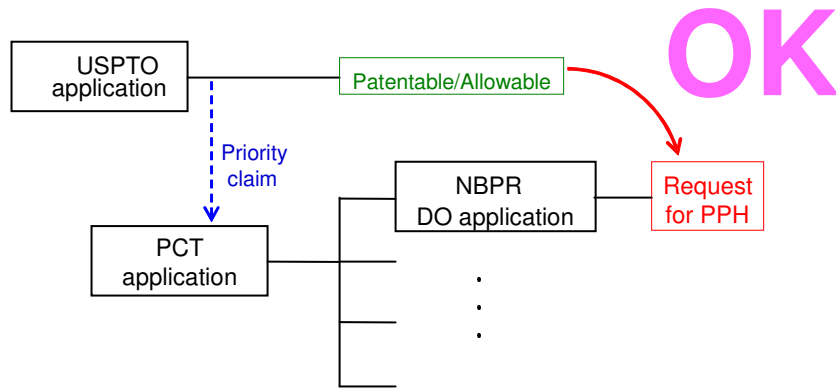

C

(Case I)
- Paris route & Complex priority -

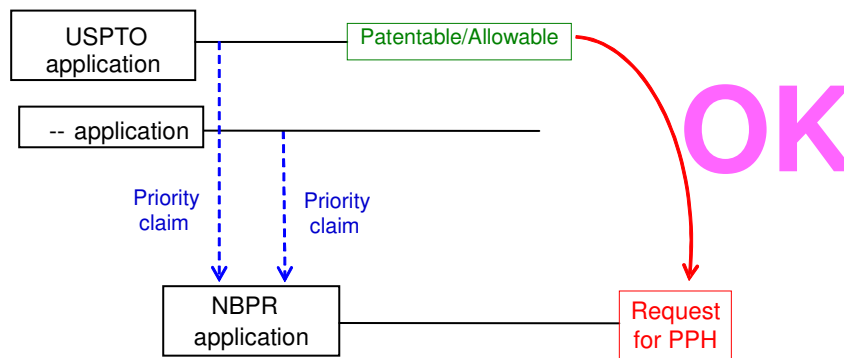

-- : any office

D

(Case I)
- Paris route & divisional application -

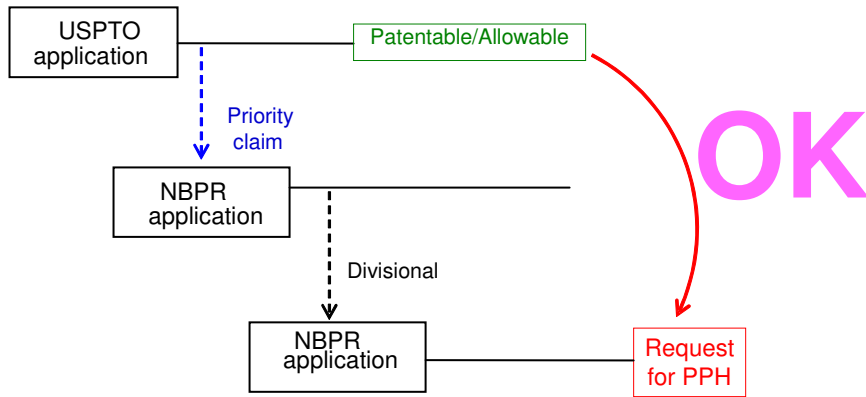

E

(Case II)
- Paris route -

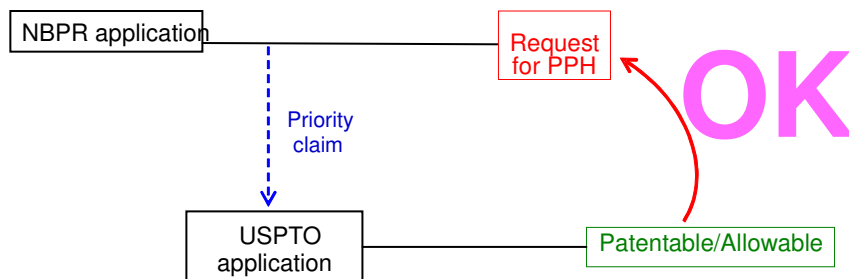

F

(Case II)
- PCT route -

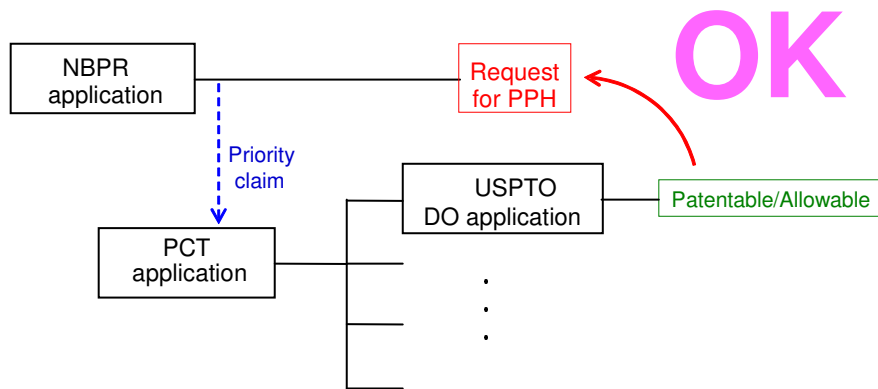

G

(Case II)
- Paris route & Complex priority -

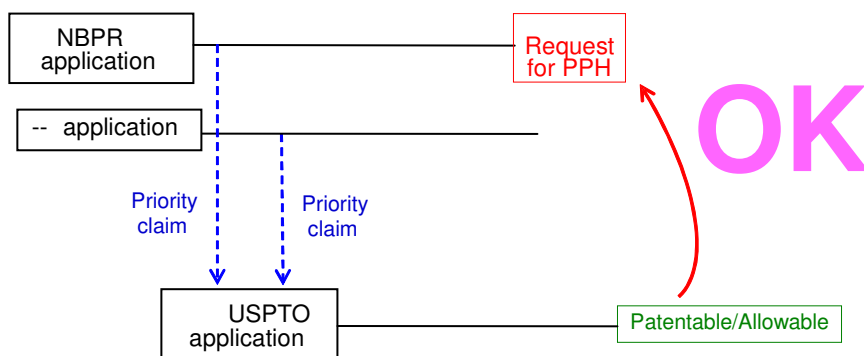

-- : any office

H

(Case III)

- Paris route, Internal priority -

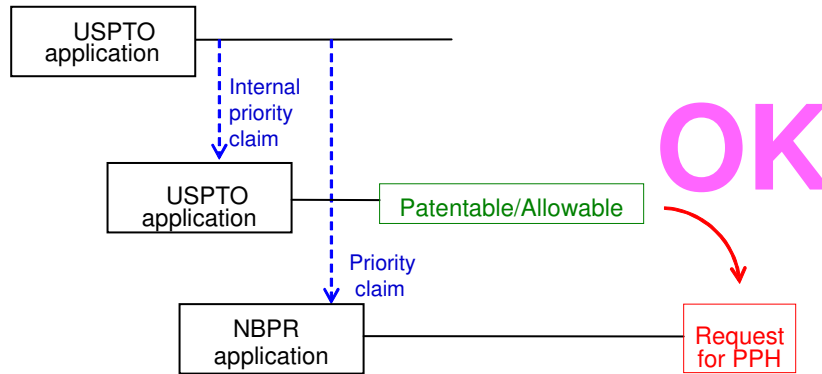

I

(Case III)

- Paris route, but the first application is from the third country -

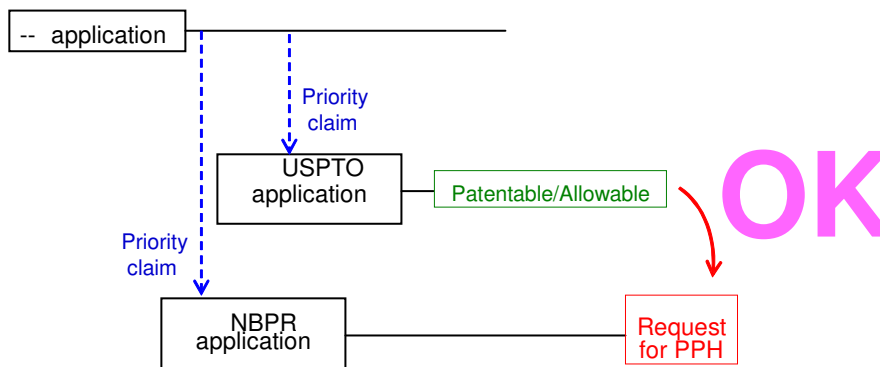

-- : the office other than the USPTO and the NBPR

J

(Case III)

- PCT route, but the first application is from the third country -

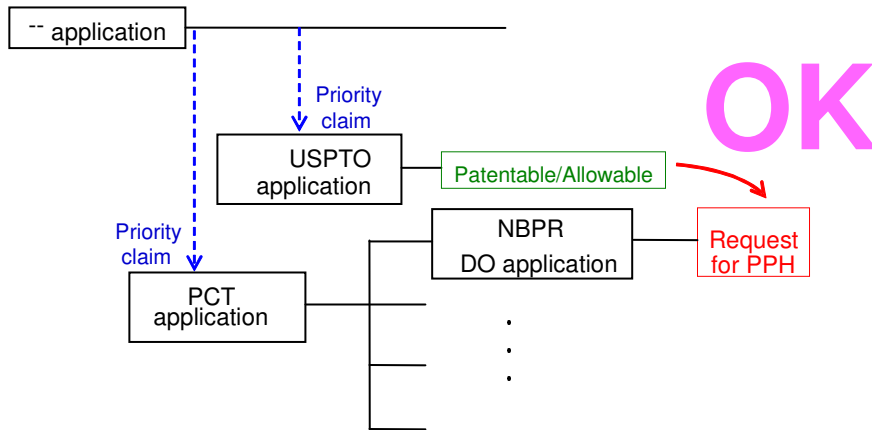

-- : the office other than the JPO and the NBPR

K

(Case III)

- PCT route -

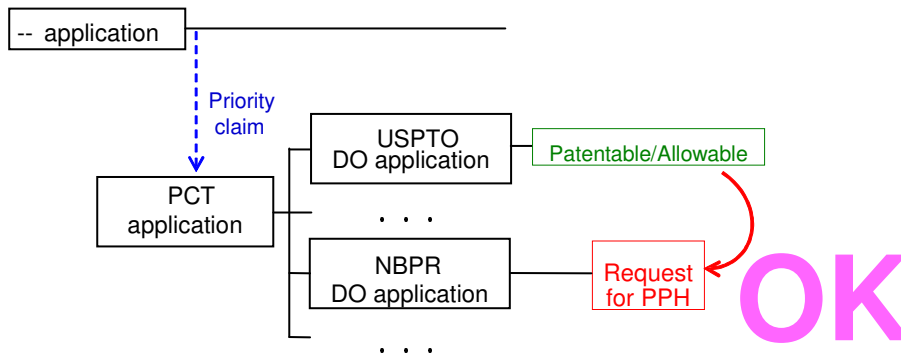

-- : any office

L

(Case III)
- Direct PCT & PCT route -

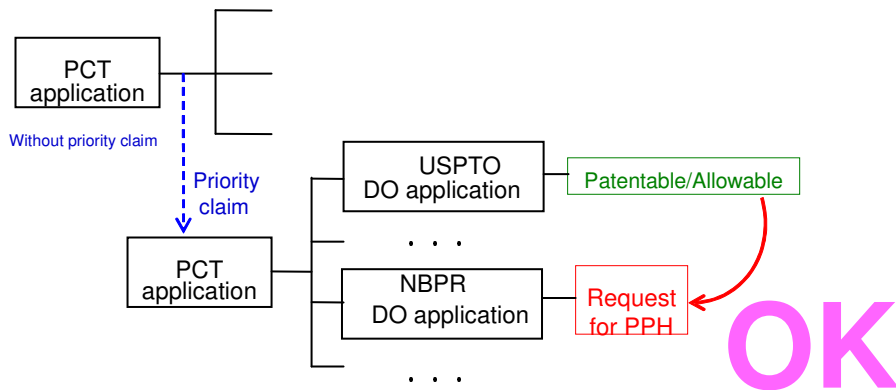

M

(Case IV)
- Direct PCT route -

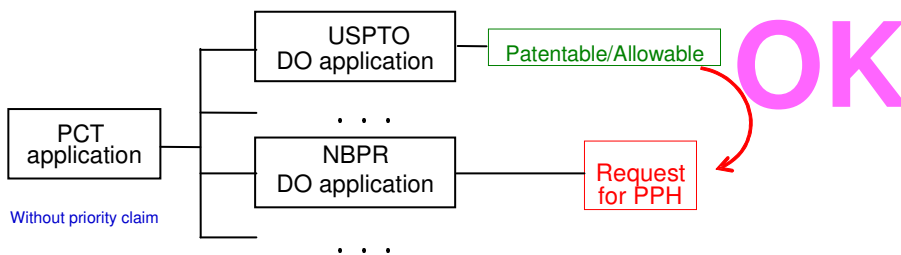

N

A case not meeting requirement (d)
_ Examination has begun before a request for PPH _

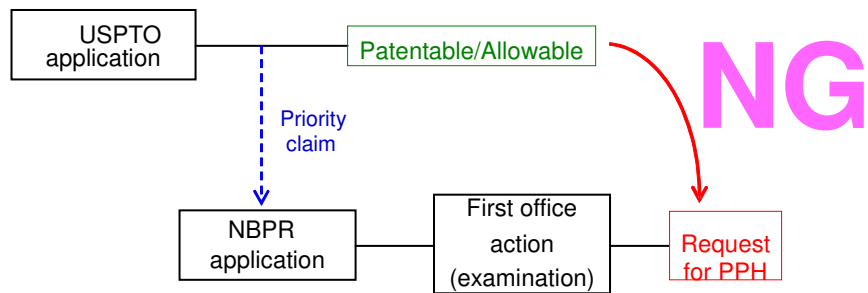

ANNEX 2

Examples of the applications eligible for PCT-PPH

(A) The application is a national phase application of the corresponding international application.

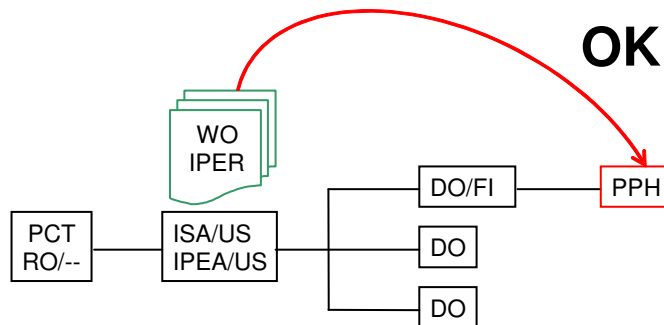

**(A') The application is a national phase application of the corresponding international application.
(The corresponding international application claims priority from a national application.)**

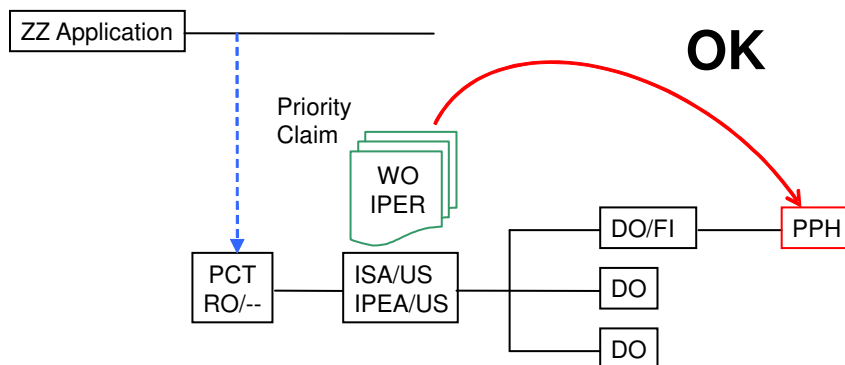

(A'') The application is a national phase application of the corresponding international application.
 (The corresponding international application claims priority from an international application.)

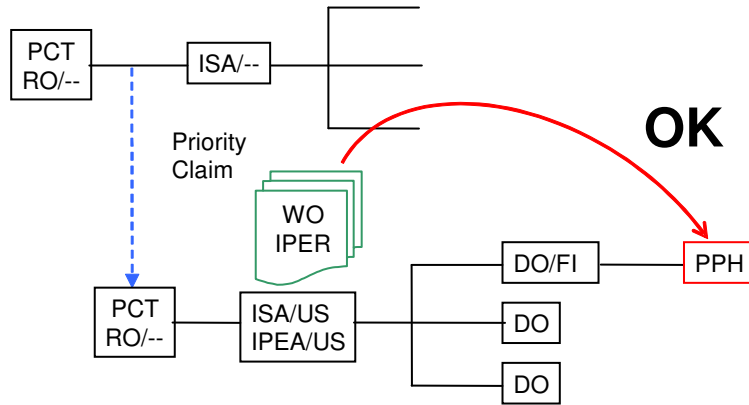

(B) The application is a national application as a basis of the priority claim of the corresponding international application.

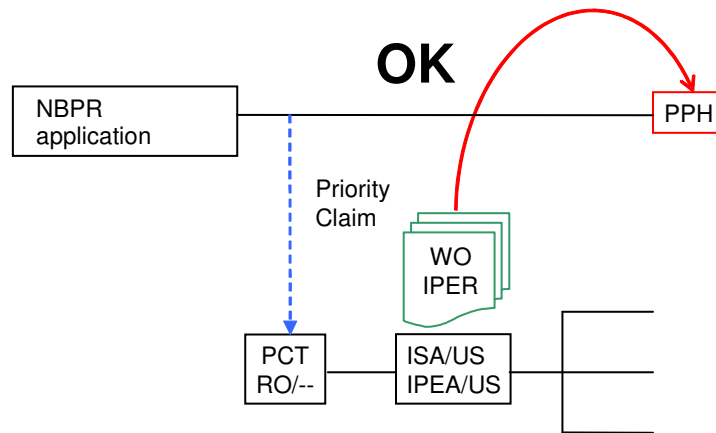

(C) The application is a national phase application of an international application claiming priority from the corresponding international application.

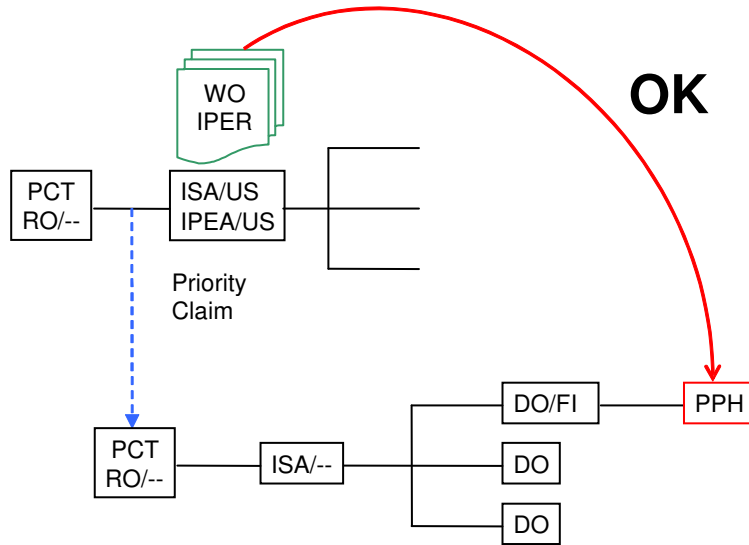

(D) The application is a national application claiming foreign/domestic priority from the corresponding international application.

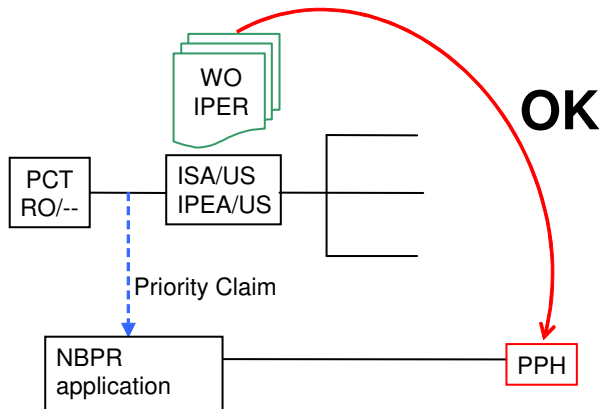

(E1) The application is a divisional application of an application which satisfies the requirement (A).

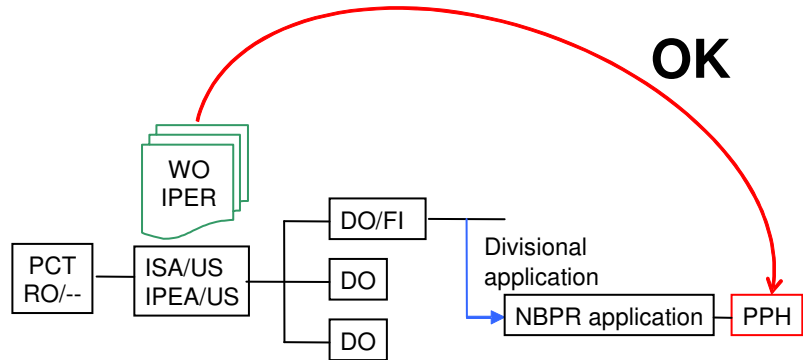

(E2) The application is an application claiming domestic priority from an application which satisfies the requirement (B).

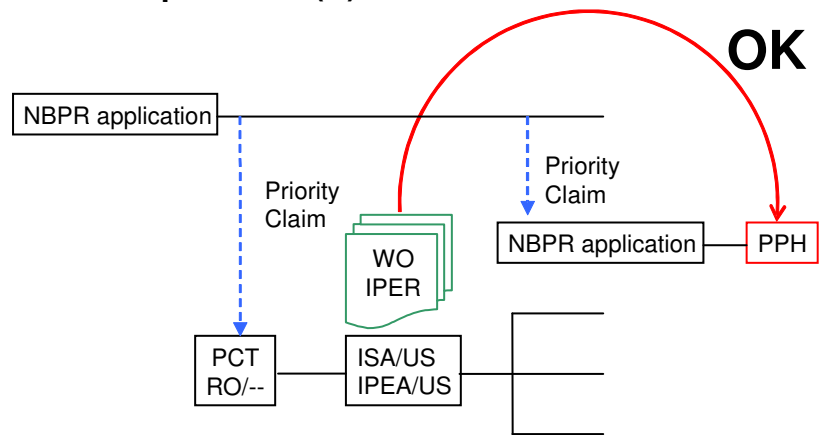

ANNEX 3

PPH REQUEST

Request for Accelerated Examination at the NBPR Under the Patent Prosecution Highway Pilot Program Between the NBPR and the USPTO

- 1 NBPR application number:
Corresponding USPTO application number(s):

- 2 **Either:**
 - a) Copy of USPTO office action(s) attached:
 - or**
 - b) USPTO office action(s) available via Public PAIR:
 - or**
 - c) USPTO office action(s) on file from previous PPH application:
NBPR application number:

- 3 **Either:**
 - a) Copy of claims of corresponding USPTO application attached:
 - or**
 - b) Claims of corresponding USPTO application available via Public PAIR:
 - or**
 - c) USPTO application claims on file from previous PPH application:
NBPR application number:

- 4 Claim correspondence table completed:

ANNEX 4

PCT-PPH REQUEST

Request for Accelerated Examination at the NBPR using the PCT international work products under the Patent Prosecution Highway Pilot Program Between the NBPR and the USPTO (PCT-PPH pilot program)

FI application number:

Corresponding PCT application number:

For the purposes of participation in the PPH, the following documents should be attached/are required:

1. Either:
 - 1.1 A copy of WO-ISA or IPER and translation thereof in English or Finnish
or
 - Request to obtain documents in 1.1 via PATENTSCOPE®

2. Either:
 - 2.1 A copy of all claims determined to be patentable/allowable by the ISA or IPEA
or
 - Request to obtain documents in 2.1 via the PATENTSCOPE®

3. Translation of the documents in 2. in English or Finish.

4. Copies of all documents cited in the WO-ISA or IPER (except for patent documents)

5. Claims correspondence table

This notice is accepted by

Date: _____

RAUNI HAGMAN
Director General
National Board of Patents and
Registration of Finland